

TCL122

3-WHEEL DUAL-DRIVE SUPERCOMPACT COUNTERBALANCE FORKLIFT 1.2T

 1200 kg  4500 mm  Li-Ion



TCL122 is a compact 80V lithium-ion 3 wheels forklift designed for applications in tight indoor spaces, offering small turning radius and a low overall height that enables work in narrow aisles, low-clearance areas, mezzanines, and cargo lifts. Its dual-drive PMS Motor ensures smooth, agile handling, while automatic stop on ramp and speed reduction on turns support safe operation. TCL122 is the ideal forklift for light to medium-duty applications where maneuverability are the main priorities.

SPECIFICATION	REF	UNIT	VALUE
Manufacturer			EP
Model designation			TCL122
Battery voltage/nominal capacity		V/Ah	80/50
Rated capacity	Q	kg	1200
Load centre distance	c	mm	500
Service weight		kg	2469
Height, mast lowered	h_1	mm	2048
Lift	h_3	mm	3000
Height, mast extended	h_4	mm	4055
Overall length	l_1	mm	2732
Overall width	b_1/b_2	mm	1020
Length to face of forks	l_2	mm	1812
Fork dimensions	s/e/l	mm	40X100X920
Turning radius	Wa	mm	1519
Drive			Electric
Operator type			Seated

Features

Compact size with high operator comfort

With its low service weight, compact size, and overhead guard height (h_6) < 2000mm, TCL is ideal for mezzanines and cargo lifts usage and in narrow spaces like intensive warehousing and HGVs.

Despite its compactness, the TCL prioritizes operator comfort with an ergonomic design, providing an ample legroom of 464mm and a good visibility for a comfortable operating experience.

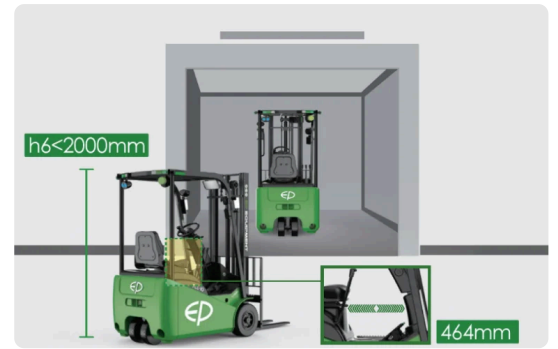

Dual drive motors

The unique dual drive motor system, unmatched in this capacity segment, gives the TCL outstanding traction and ultra-responsive steering. Together with its agile 3-wheel design, it turns on the spot and delivers an exceptionally tight turning radius — perfect for navigating busy, space-restricted environments. With a top speed of 13 km/h and powerful acceleration, the TCL ensures fast pallet handling and boosts everyday work efficiency

80V Li-ion & PMSM technology

Equipped with 80V Li-ion battery and integrated single phase fast charger as standard, the TCL supports opportunity charging with no maintenance. Additionally, the TCL employs advanced permanent magnet synchronous motor (PMSM) technology and can achieve 10-15% energy savings and extend runtime by 10% compared to conventional motors.

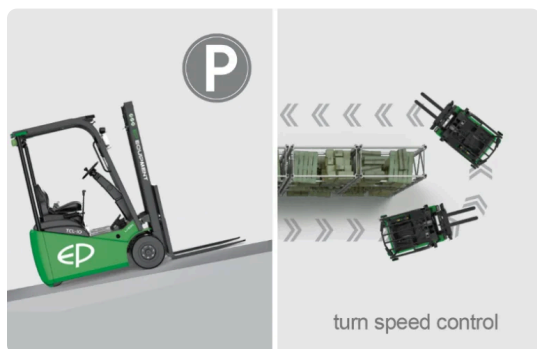

Top class features

The TCL features automatic stop on ramp and electric parking brake which can protect the forklift from accidentally rolling back when parked on a slope. It's also equipped with turn speed control as standard for maximum productivity safety and stability even in the tightest of corners.

VDI Chart

	SPECIFICATION	REF	UNIT	VALUE
1.1	Manufacturer			EP
1.2	Model designation			TCL122
1.3	Drive			Electric
1.4	Operator type			Seated
1.5	Rated capacity	Q	kg	1200
1.6	Load centre distance	c	mm	500
1.8	Load distance, centre of drive axle to fork	x	mm	357
1.9	Wheelbase	y	mm	1300
2.1	Service weight		kg	2469
2.2	Axle loading, laden front/rear		kg	3288/381
2.3	Axle loading, unladen front/rear		kg	1288/1181
3.1	Tyres			Solidrubber
3.2	Tyre size, front		mm	18x7-8
3.3	Tyre size, rear		mm	15x4.5-8
3.5	Wheels, number front/rear (x=drive wheels)			2x/2
3.6	Tread width, front	b ₁₀	mm	850
3.7	Tread width, rear	b ₁₁	mm	210
4.1	Tilt of mast/fork carriage forward/backward	α/β	°	6/6
4.2	Height, mast lowered	h ₁	mm	2048
4.2.1	Overall height		mm	4065
4.3	Free lift	h ₂	mm	105
4.4	Lift	h ₃	mm	3000
4.5	Height, mast extended	h ₄	mm	4055
4.7	Height of overhead guard (cabin)	h ₆	mm	1988
4.8	Seat height relating to SIP/stand height	h ₇	mm	948
4.12	Coupling height	h ₁₀	mm	513
4.19	Overall length	l ₁	mm	2732
4.20	Length to face of forks	l ₂	mm	1812
4.21	Overall width	b ₁ /b ₂	mm	1020
4.22	Fork dimensions	s/e/l	mm	40X100X920
4.23	Fork carriage ISO 2328, class/type A, B			2A
4.24	Fork carriage width		mm	960

SPECIFICATION	REF	UNIT	VALUE
4.31	Ground clearance, laden, below mast	mm	93
4.32	Ground clearance, centre of wheelbase	m ₂	mm 115
4.34.1	Aisle width for pallets 1000×1200 crossways	Ast	mm 3207
4.34.2	Aisle width for pallets 800 × 1200 lengthways	Ast	mm 3336
4.35	Turning radius	Wa	mm 1519
5.1	Travel speed, laden/unladen	km/h	11/13
5.2	Lift speed, laden/unladen	m/s	0.28/0.35
5.3	Lowering speed, laden/unladen	m/s	0.32/0.36
5.5	Drawbar pull, laden/unladen		3288/381
5.6	Max. drawbar pull, laden/unladen	N	Max. drawbar pull, laden/unladen
5.8	Max. gradeability, laden/unladen	%	13/15
5.10	Service brake		Electromagnetic
5.11	Parking brake		Electromagnetic
6.1	Drive motor rating S2 60 min	kW	2.0X2
6.2	Lift motor rating at S3 15%	kW	7
6.4	Battery voltage/nominal capacity	V/Ah	80/50
6.4.3	Battery type		Li-Ion
6.5	Battery weight	kg	61
8.1	Type of drive unit		PMSM
10.5	Steering design		Hydraulic
10.7	Sound pressure level at the driver's seat	dB(A)	68
15.1	Charger output current	A	35

Subject to modification of specifications and designs without prior notice as part of continuous product improvement. Images and technical data shown may include optional features and are provided for reference only. All dimensions are subject to standard manufacturing tolerances.

RATED CAPACITIES AND LOAD CENTERES GRAPH

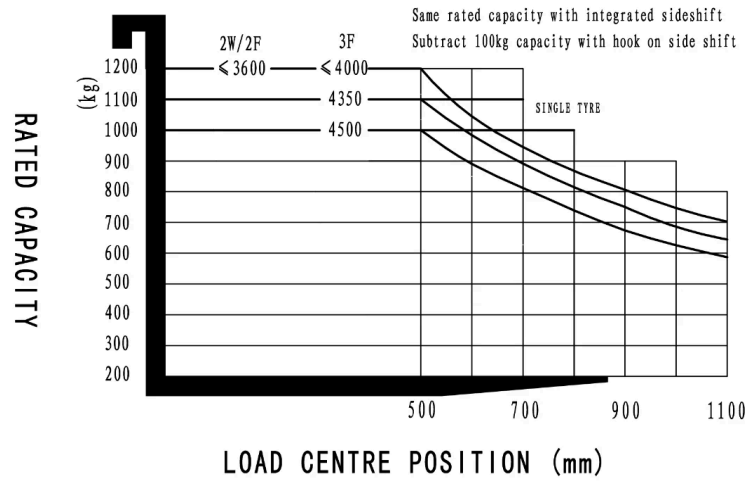

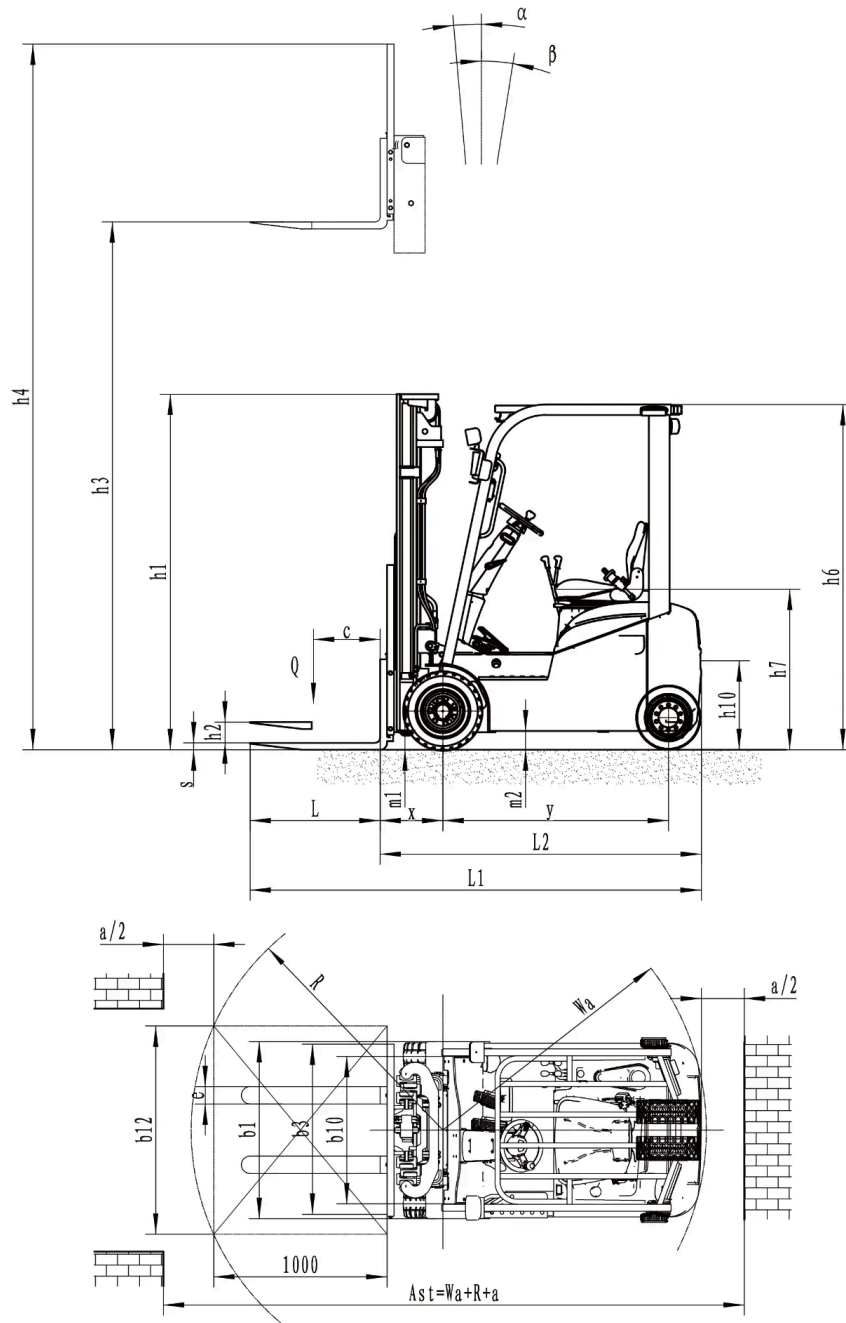

Mast Options

MAST TYPE	LIFT HEIGHT (H3, MM)	MAST LOWERED HEIGHT (H1, MM)	MAST EXTENDED HEIGHT, NO BACKREST (H4, MM)	MAST EXTENDED HEIGHT, WITH BACKREST (H4, MM)	FREE LIFT HEIGHT, NO BACKREST (H2, MM)	FREE LIFT HEIGHT, WITH BACKREST (H2, MM)
2-Standard Mast	2500	1798	3045	3555	105	105
2-Standard Mast	2700	1898	3245	3755	105	105

MAST TYPE	LIFT HEIGHT (H3, MM)	MAST LOWERED HEIGHT (H1, MM)	MAST EXTENDED HEIGHT, NO BACKREST (H4, MM)	MAST EXTENDED HEIGHT, WITH BACKREST (H4, MM)	FREE LIFT HEIGHT, NO BACKREST (H2, MM)	FREE LIFT HEIGHT, WITH BACKREST (H2, MM)
2-Standard Mast	3000	2048	3545	4055	105	105
2-Standard Mast	3300	2198	3845	4355	105	105
2-Standard Mast	3600	2348	4145	4655	105	105
2-Free Mast	2500	1773	3045	3555	1280	745
2-Free Mast	2700	1873	3245	3755	1380	845
2-Free Mast	3000	2023	3545	4055	1530	995
2-Free Mast	3300	2173	3845	4355	1680	1145
2-Free Mast	3600	2323	4145	4655	1830	1295
3-Free Mast	4000	1883	4546	5055	1390	855
3-Free Mast	4300	1983	4826	5335	1490	955
3-Free Mast	4500	2048	5046	5555	1555	1020

Options

ITEM	OPTIONS (optional items marked in yellow)
Fork dimension	100*40*920 100*40*1070 100*40*1150 100*40*1200 100*40*1220 100*40*1370
Front wheel material	Normal solid Non-marking solid
Rear wheel material	Normal solid Non-marking solid
Battery capacity	80V50Ah 80V100Ah
Charger	80V-35A Single-phase built-in charger
Battery indicator	With hourmeter
Seat type	Regular+ safety belt switch Comfortable + safety belt switch Suspension + safety belt switch
Attachments	No Built-in sidershifter External shifter
Traction pin	Yes and not customised
Front lamp	LED
Rear lamp	No LED
Warning lamp	Yes and not customised
Blue lamp	No Rear Front Front and rear

ITEM	OPTIONS (optional items marked in yellow)
Area warning lamp	No Both side Both side and rear
Rearview mirror	One in front Two on sides and one in front
Buzzer	Yes and not customised
OPS system	Yes and not customised
USB interface	No
Telematics	Yes and not customised
Cabin	No
Overhead guard	Yes and not customised
Clamp interlock	No
Anti-static chain	Yes and not customised
Turn signal light	LED
AS/NZS function package	No Only for Australia standard
Turn speed control	Yes and not customised
Heating system during lithium battery charging	No Yes and not customised
Operator identification device	Card reader
Lifting electronic limit	No
Hydraulic system operating mode	Mechanical lever
Rear armrest horn	No