

EP EQUIPMENT <sup>PRO</sup>**EFL35 PRO****4-WHEEL LI-ION COUNTERBALANCE FORKLIFT 3.5T**
 3500 kg
  6000 mm
  80 V Li-Ion

Built to perform across diverse environments, the EFL Pro Series excels in warehouses, factories, logistics centers, ports, and construction yards. Its high ground clearance, large tires and IPX4 water resistance enable operation on uneven outdoor terrain, while its compact turning radius and quiet, emissionfree power make it ideal for indoor use as well. Designed to replace traditional diesel forklifts, the EFL Pro provides high performance with reduced operating costs

SPECIFICATION	REF	UNIT	VALUE
Battery type			Li-Ion
Battery nominal capacity K5		Ah	280
Battery voltage		V	80
Rated capacity	Q	kg	3500
Load centre distance	c	mm	500
Service weight		kg	5250
Height, mast lowered	h1	mm	2065
Lift	h3	mm	3000
Height, mast extended	h4	mm	4130
Overall length	l1	mm	3682
Overall width	b1/b2	mm	1210
Length to face of forks	l2	mm	2612
Fork dimensions	s/e/l	mm	50×122×1070
Turning radius	Wa	mm	2395
Manufacturer			EP
Model designation			EFL 35 PRO



## Unmatched Performance and great operator experience

Powered by a 17kW AC driving motor and 30kW PMS pump motor system, the EFL PRO achieves performance, gradeability and residual capacity in line with the best electric forklift with the advantage of the high ground clearance, the big size tires and robust chassis.

EFL PRO hydraulic system feature:

- Full-proportion solenoid valve for a more accurate micro-control
- PMS pump motor and screw type pump for precise and silent hydraulic operation
- Big diameter hydraulic tubing for high oil flow also on the attachments



## Sleek Appearance with Enhanced Versatility

The EFL PRO Series combines a sleek, fully-molded design with outstanding stability, thanks to its extended 1753 mm wheelbase. Despite its robust stance, key dimensions—such as width and turning radius—remain comparable to standard electric forklifts, ensuring versatility in any application. Modern LED lighting enhances visibility and reinforces its contemporary look, while the electric parking brake and automatic stop on ramp further elevate safety and control

## State of the art controls on the armrest

Multiple functions are integrated at the palm-size end with fingertip or joystick and includes:

forward/reverse direction switch, lifting/lowering, tilting, sideshift and 4th way, horn, turning light switch, Storage box and USB port, emergency switch

Optional: fork leveling button, clamp interlock button, 5th way button switch can complete the operator controls





## Informative and Multi-functional Full-touch Display

The new OLED touchscreen display provides real-time monitoring of all key forklift operating parameters, including battery state of charge, driving speed, travel direction, wheel angle, operating hours, date and time. Optional functions such as mast tilt angle, lift height and load weight indicators can also be integrated. Thanks to its touch interface, the operator can easily control all auxiliary systems, including the lighting system, wipers, and cabin heater.

## Ergonomic Cabin for Fatigue-free and Convenient Operation

The EFL PRO's ergonomic design begins the moment the operator steps aboard, thanks to the largest access step in its class. Once inside, the EFL PRO features a spacious driving area with a standard suspended seat with armrest. A reduced-size steering wheel, a tempered glass roof for enhanced visibility, and practical storage compartments further elevate the operator experience. For ease of service, power and auxiliary controllers are housed in a protected area accessible through removable panels.



## Revolutionary Li-ion Battery and Charging System

At the core of the EFL PRO Series is EP's breakthrough Li-ion technology — a new Li-ion battery system composed of three independent battery modules operating in series to achieve 80V. Each module functions autonomously, ensuring consistent performance and enhanced reliability. This battery architecture enables power from 280Ah to 560Ah or 628Ah, allowing the EFL PRO to adapt its endurance to a wide range of applications. Furthermore, through a dedicated upgrade kit, the dealer is able to adjust such battery power capacity to meet evolving customer requirements.

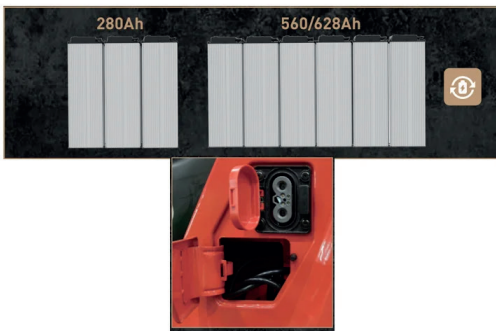

Additionally, each battery module can be repaired or replaced individually, eliminating the costly full-pack replacements typically required when single cells fail. For further charging convenience, both integrated charging and external charging port are available on one truck making EFL PRO flexible for all kinds of applications needs.

## Complete configuration including Telematic and innovative options

EFL PRO comes standard with ergonomic armrest equipped with fingertip or joystick hydraulic controls, automatic speed reduction on turns and with telematic system that allows to manage the fleet and the rental activities in an effective and efficient manner. The system tracks data for truck and battery usage, like uptime, battery status and real-time location. It allows dealers to monitor and analyze assets conditions, providing remote diagnostics and improving the efficiency of fleet management.

The following items are available as optional equipment:

Full cabin with integrated heater on the dashboard and operator feet;  
Load-leveling function activated at the press of a single button;  
Load height indicator;  
Load weight indicator;  
Panoramic OHG with glass roof;  
360° Panorama System with human recognition and collision warning (no CE);  
; Ambient-noise Adaptive Buzzer(no CE)



## VDI Chart

	SPECIFICATION	REF	UNIT	VALUE
1.1	Manufacturer			EP
1.2	Model designation			EFL 35 PRO



SPECIFICATION	REF	UNIT	VALUE
<b>1.3</b>			Electric
<b>1.4</b>			Seated
<b>1.5</b>	Q	kg	3500
<b>1.6</b>	c	mm	500
<b>1.8</b>	x	mm	486
<b>1.9</b>	y	mm	1753
<b>2.1</b>		kg	5250
<b>2.2</b>		kg	7748/1002
<b>2.3</b>		kg	2267/2983
<b>3.1</b>			Pneumatic
<b>3.2</b>		mm	28X9-15-14PR
<b>3.3</b>		mm	6.50-10-10PR
<b>3.5</b>			2x/ 2
<b>3.6</b>	b10	mm	1010
<b>3.7</b>	b11	mm	980
<b>4.1</b>		°	6/ 6
<b>4.2</b>	h1	mm	2065
<b>4.3</b>	h2	mm	135
<b>4.4</b>	h3	mm	3000
<b>4.5</b>	h4	mm	4130
<b>4.7</b>		mm	2170
<b>4.8</b>		mm	1138
<b>4.12</b>		mm	510
<b>4.19</b>	l1	mm	3682
<b>4.20</b>	l2	mm	2612
<b>4.21</b>	b1/b2	mm	1210
<b>4.22</b>	s/e/l	mm	50×122×1070
<b>4.23</b>			3A
<b>4.24</b>		mm	1100
<b>4.31</b>		mm	130
<b>4.32</b>	m2	mm	165
<b>4.34.1</b>	Ast	mm	4081
<b>4.34.2</b>	Ast	mm	4281
<b>4.35</b>	Wa	mm	2395



SPECIFICATION	REF	UNIT	VALUE
<b>5.1</b>	Travel speed, laden/unladen	km/h	19/20
<b>5.2</b>	Lift speed, laden/unladen	m/s	0.49/0.52
<b>5.3</b>	Lowering speed, laden/unladen	m/s	0.43/0.44
<b>5.5</b>	Drawbar pull, laden/unladen		5924
<b>5.6</b>	Max. drawbar pull, laden/unladen		22350
<b>5.8</b>	Max. gradeability, laden/unladen	%	20/28
<b>5.10</b>	Service brake		Mechanical/Hydraulic
<b>5.11</b>	Parking brake		Electromagnetic
<b>6.1</b>	Drive motor rating S2 60 min	kW	17
<b>6.2</b>	Lift motor rating at S3 15%	kW	30
<b>6.4</b>	Battery nominal capacity K5	Ah	280
<b>6.4</b>	Battery voltage	V	80
<b>6.4.1</b>	Battery type		Li-Ion
<b>6.5</b>	Battery weight	kg	184
<b>6.6</b>	Energy consumption according to DIN EN 16796	kWh/h	9.34
<b>6.7</b>	Turnover output according to VDI 2198		217
<b>6.8</b>	Turnover efficiency according to VDI 2198		22.96
<b>8.1</b>	Type of drive unit		AC
<b>10.1</b>	Operating pressure for attachments	bar	180
<b>10.2</b>	Oil volume for attachments	l/min	35
<b>10.5</b>	Steering design		Hydraulic
<b>10.7</b>	Sound pressure level at the driver's seat	dB(A)	70



## EFL 35 PRO

### RATED CAPACITIES GRAPH

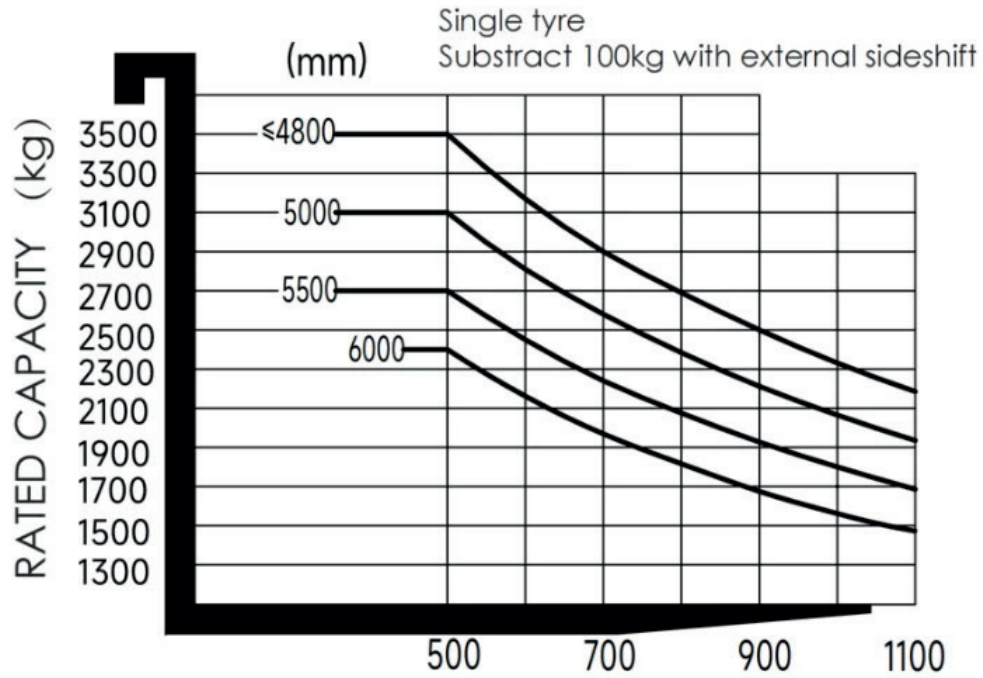

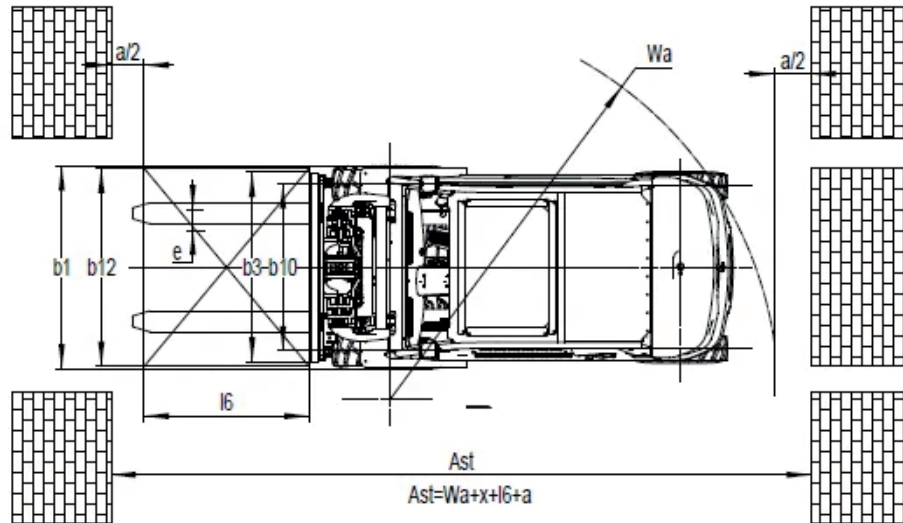
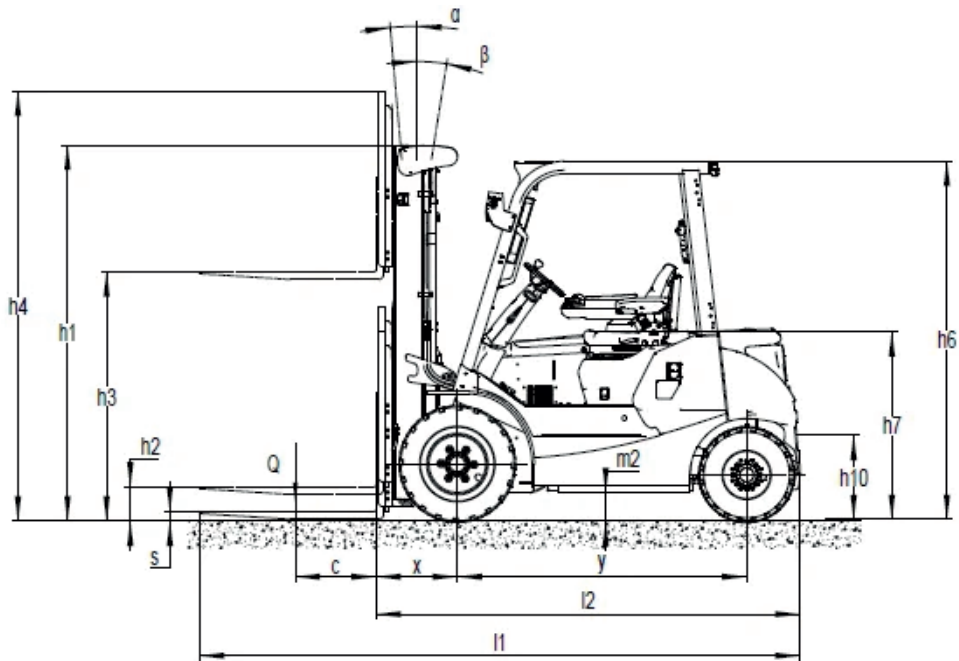

## Mast Options

MAST TYPE	LIFT HEIGHT (H3, MM)	MAST LOWERED HEIGHT (H1, MM)	MAST EXTENDED HEIGHT, NO BACKREST (H4, MM)	MAST EXTENDED HEIGHT, WITH BACKREST (H4, MM)	FREE LIFT HEIGHT, NO BACKREST (H2, MM)	FREE LIFT HEIGHT, WITH BACKREST (H2, MM)
2-Standard Mast	2700	1915	3365	3830	135	135
2-Standard Mast	3000	2065	3665	4130	135	135
2-Standard Mast	3300	2215	3965	4430	135	135
2-Standard Mast	3500	2315	4165	4630	135	135
2-Standard Mast	3600	2365	4265	4730	135	135



MAST TYPE	LIFT HEIGHT (H3, MM)	MAST LOWERED HEIGHT (H1, MM)	MAST EXTENDED HEIGHT, NO BACKREST (H4, MM)	MAST EXTENDED HEIGHT, WITH BACKREST (H4, MM)	FREE LIFT HEIGHT, NO BACKREST (H2, MM)	FREE LIFT HEIGHT, WITH BACKREST (H2, MM)
2-Standard Mast	4000	2615	4665	5130	135	135
2-Standard Mast	4500	2865	5165	5630	135	135
2-Free Mast	3000	2045	3715	4175	1410	950
2-Free Mast	3300	2195	4015	4475	1560	1100
2-Free Mast	3600	2345	4315	4775	1710	1250
3-Free Mast	4300	2080	5030	5435	1390	985
3-Free Mast	4500	2160	5270	5675	1470	1065
3-Free Mast	4800	2265	5570	5975	1575	1170
3-Free Mast	5000	2350	5720	6125	1660	1255
3-Free Mast	5500	2600	6220	6625	1910	1505
3-Free Mast	6000	2850	6720	7125	2160	1755

## Options

ITEM	OPTIONS [optional items marked in yellow]
Fork dimension	122*50*1070   122*50*1150   122*50*1220   122*50*1370   122*50*1520
Front wheel material	Pneumatic   Normal solid   Traceless solid
Rear wheel material	Pneumatic   Normal solid   Traceless solid
Battery capacity	80V280AH   80V560AH   80V628AH (NON-CE)
Charger	80V65A (NON-CE)   80V60A (CE)   80V35A integrated   80V60A integrated   80V130A   80V150A   80V200A (560/628AH)
Battery display indicator (BDI)	With time (Bluetooth)
Seat type	Comfortable + safety belt switch (41)   Suspension seat with armrest and safety belt switch   GRAMMER-MSG65
Attachments	Built-in sideshifter   External shifter   Fork positionr with sideshift   External shifter with adjustable forks   Clamp
Traction pin	Yes and not customized
Anti-static chain	Yes and not customized
Front lamp	LED



ITEM	OPTIONS (optional items marked in yellow)
Rear lamp	No   LED
Warning lamp	Yes and not customized
Steering lamp	LED
Blue lamp	No   Rear   Front and rear
Area warning lamp	No   Both sides   Both sides and rear
Rearview mirror	One in front   Two on sides and one in front
Buzzer	Regular buzzer   Ambient-noise adaptive buzzer (NON-CE)
OPS system	Yes and not customized
USB interface	Cigarette lighter+USB with A and C type
Telematics	Yes and not customized   No
Cabin	No   Basic semi-cabin   Upgraded semi-cabin   Full cabin
Overhead guard	Strip glass with anti-explosion film   Panoramic glass roof (NON-CE)
Clamp interlock	No   Yes and not customized
Special AUS/NZ options	No   Yes and not customized
Turn speed control	Yes and not customized   No
Heating system during lithium battery charging	No   Yes and not customized
Operator identification device	No   Card reader
Lifting electronic limit	No   Yes and not customized
Hydraulic control	Joystick   Fingertip
Rear armrest horn	Yes and not customized
Area Speed Limit System	No   Yes and not customized
Weighing system	No   Yes and not customized
Wiper water unit	Yes only with Cabin
Automatic Parking Brake	Yes and not customized
Height display+Forward tilt speed limit+High-position lateral shift speed control	No   Yes and not customized
Surround View System+Human recognition system	No   Yes and not customized (NON-CE)
Automatic fork leveling	No   Yes and not customized

